

Control unit for system leakage tests

Type VPM-LC (Line Check)

DUNGS[®]
Combustion Controls

8.30

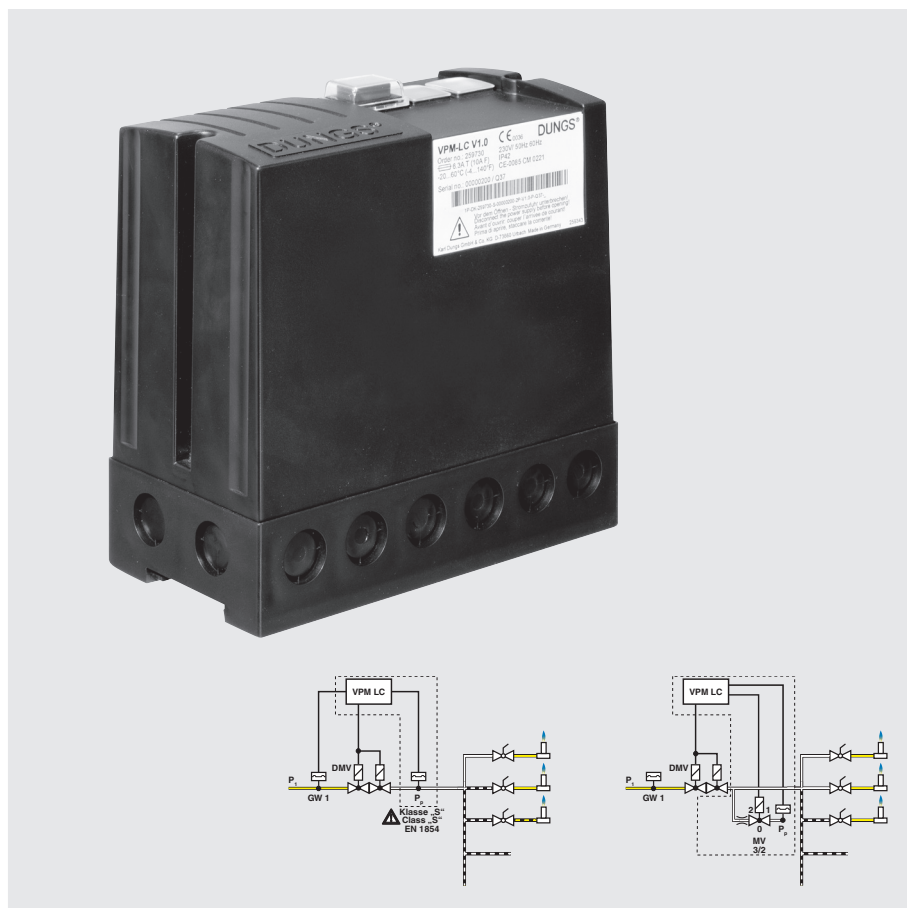

Description

The VPM-LC valve test module checks the tightness of the gas line between the central shut-off fitting (safety solenoid valve) and the gas extraction points. The number of filling attempts as well as program times can be adjusted by the user according to the system requirements.

Application

In laboratories, large-scale catering establishments and process engineering plants.

The leakage test is performed before opening a central gas shut-off valve that releases gas supply to several gas-consuming devices.

Uncontrolled escape of gas at the various extraction points is thus avoided.

Approvals

DVGW type examination certificate according to DIN EN 13611 and DIN EN 298:
DG-4115CM0413

VPM-LC meets the requirements of:

- DVGW worksheet G621:2009-11: Components of gas installations in laboratories and scientific classrooms.
- DVGW worksheet G634:1998-09: Installation of catering gas appliances in premises
- Machinery Directive 2006/42/EC
- Low Voltage Directive 2006/95/EC
- EMV 2004/108/EC

CSA approval on request

FM Approvals Class 7610

VPM-LC

Control unit for system leakage tests

Equipment: Depending on the chosen equipment option, two pressure switches, double solenoid valve and pilot valve.

VPM-LC checks the following parameters before starting:

- Tightness of the gas line system
- Closed position of shut-off devices (valves, manual valves/lab equipment)



- Inlet pressure

Monitoring during operation:





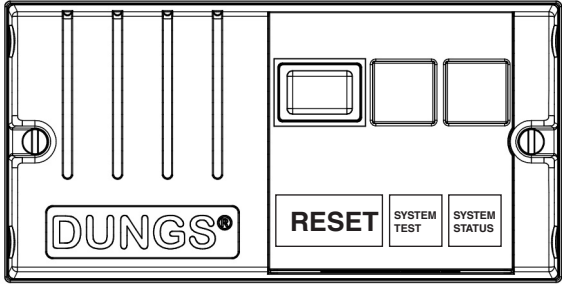





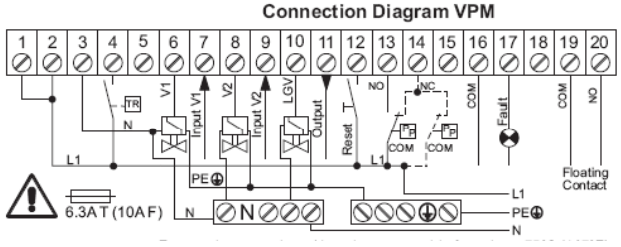

- Power failure
- Min. gas pressure

**Pressure switches/valves/pilot valves are not part of the scope of delivery!****Technical data**

Rated voltage (depending on the model)	~ (AC) 230 V +10 % / -15 % 50-60 Hz ±5 % ~ (AC) 115 V +10 % / -15 % 50-60 Hz ±5 %
Power consumption	max. 10 W
Power consumption Typical	115 V: standby 2.6 W operation 4.6 W 230 V: standby 3.1 W operation 5.4 W
Backup fuse L1	6.3A T (10A F), integrated, replaceable
Humidity	DIN 60730-1, no dewing admissible
Type of protection	IP 42
Ambient temperature	-20 °C bis +60 °C
Storage temperature	-40 °C bis +80 °C
Switch-on duration	100 %
Operational altitude	Suitable for use up to 2000 meters above sea level
Test volume	Unlimited
Medium	Any; gas type depending on pressure switch and valve
Inlet pressure	Any; depending on pressure switch and valve
Multifunction output (MFA)	Number of operating cycles V1 > 100000 (terminal 19 + 20, potential-free). Further settings possible via VisionBox + parameter change: 1. Freely selectable number of operating cycles up to 6.5 million (standard 100,000) 2. Signal output while the test is running or while voltage is applied or release for water or power supply. 3. Signal after successful switch-off
Program sequence	Line check before start
Test times can be set	DIP switches can be used to select predefined test times of, enabling optimal setting in case of different test volumes, inlet pressures and leakage rates. Alternatively, individual test times, can be set via VisionBox.
Filling attempts	Depending on the test volume, different combinations can be selected using DIP switches.
Signalling	Red/green LEDs signal various information on the program and release states or error codes.
TWI interface	Plug-in connection for DUNGS VisionBox. The VisionBox can be used to access the VPM via a PC. The VisionBox is hardware and software for VPM parameter setting. Status information and error error memory data can be read out.
Mounting position	As desired

Signalling unit			Error information		
					<p>Detailed error information via flash codes</p> <p>All LEDs are flashing:</p> <ul style="list-style-type: none"> when a key press is requested during a level change when the VPM is ready for extended unlocking
<p>MFT (RESET) = multifunction switch:</p> <p>Unlocking switch for error status ...max. 5x/15 min.</p> <p>Changeover switch to switch to the password-protected function level for service and OEM parameter setting via TWI interface by means of the VisionBox.</p>	<p>SYSTEM TEST two LEDs green / red</p>	<p>SYSTEM STATUS two LEDs green / red</p>			
	<p>Switch-on (mains): all LEDs light up as a functional test for approx. 1.5 s. Waiting for test request: Green LED's flashing slowly (4 s off, 0,125 s on). Depending on the states, the LED-V1 and LED-V2 indicators are flashing or lit constantly</p>		Constantly red	Off	System leaking
			Red flashing 1x	Red flashing 1x	not relevant
			Red flashing 2x	Red flashing 2x	Filling error
			Red flashing 3x	Red flashing 3x	Wrong position of DIP switch
			Red flashing 4x	Red flashing 4x	Unlock failed
			Red flashing 5x	Red flashing 5x	Power on V before test completed
			Constantly red	Constantly red	...all other errors
			Constantly green	Constantly green	Release signal

Application information (DVGW worksheet/Germany)	
G 621: 2009-11	Gas systems in laboratories and scientific classrooms, installation and operation
G 631 (A): 2012	Installation of catering gas appliances in premises. Special requirements for combustion air supply and exhaust gas evacuation

Electrical connection	⊘	Outputs		Electrical data	
 <p>The sum of the currents of all safety-related consumers must not exceed 5 A! The sum of the currents of all consumers must not exceed 6.3 A (10 A).</p>	11	 → V1	Release (bridged to 7)	115/230 VAC / 5 A cos φ = 1 Minimum load 0.5 W	
	6		V (DMV)	115/230 VAC / 2 A cos φ = 1 Minimum load 0.5 W	
	10		MV 3/2	115/230 VAC / 2 A cos φ = 1 Minimum load 0.5 W	
	16		External fault	115/230 VAC / 1 A cos φ = 1	
	17		MFA	115/230 VAC / 1 A cos φ = 1	
	19		MFA	115/230 VAC / 1 A cos φ = 1	
	20		MFA	115/230 VAC / 1 A cos φ = 1	
	⊘	Inputs		Electrical data	
	4		TR	Test request	115/230 VAC
	13		Pp1	115/230 VAC normally open	
14		Pp2	115/230 VAC normally closed		
12		Remote unlocking	115/230 VAC		

Modification of the program sequence by an application-specific setting of the B/C DIP switches

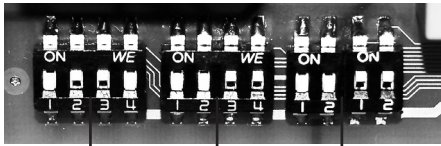

AAAA (fixed) BBBB (variable) CCCC (variable)



0110



xxxx



xxxx



A Test sequence	B t_{test} test time		C Number of venting or filling attempts	
0110	1100	10 s		
	0110	55 s	0110	Filling 1
	1001	30 s	1001	Filling 10
	0011	55 s The following can be changed via the software: P23: Test time. If this switch position is used, parameter setting should be checked via the VisionBox.	0011	Filling 3 The following can be changed via the software: P31: Number of filling operations If this switch position is used, parameter setting should be checked via the VisionBox.
As-delivered configuration				
0110		0000		0000

Installation examples



The functional principle must be selected in accordance with the local regulations!

1	Line check via gas pressure switch without idle state control, DMV	
---	System component Line check: VPM-LC, Pp according to DIN 1854, Class "S"	
	The manual valves are checked as to whether they are closed. If one of the manual valves is open, no pressure can built up. The tightness of the DMV is not checked.	
		DIP-Mode: A: 0110 B: xxxx C: 0110 0011, ❶ 1001 Parameter: ---
2	Direct line check via gas pressure switch with idle state control, MV	
---	System component Valve check: VPM-LC, Pp, shutter, MV 3/2 A shutter diameter of 0.3 mm and $p_e = 50 \text{ mbar}$ results in a leakage rate $Q_p = 16 \text{ L}_{\text{air}}/\text{h}$	
	The manual valves are checked as to whether they are closed. If one of the manual valves is open, no pressure can built up. The tightness of the DMV is not checked.	
≡	Leakage rate $Q_p = 16 \text{ l}_{\text{air}}/\text{h}$ with nozzle diameter 0.3 mm @ $p_e = 50 \text{ mbar}$	
		DIP-Mode: A: 0110 B: xxxx C: 0110 0011, ❶ 1001 Parameter: P15 = 1
Attention ❶: If this switch position is used, parameter setting should be checked via the VisionBox.		

Version		Description	Order No.
Complete device		VPM-LC cpl. 230 VAC	259 146
		VPM-LC cpl. 115 VAC	259 147
Top part		VPM-LC 230 VAC	259 730
		VPM-LC 115 VAC	259 731
Base		1 piece	259 694
		48 piece	259 695

Dimensions

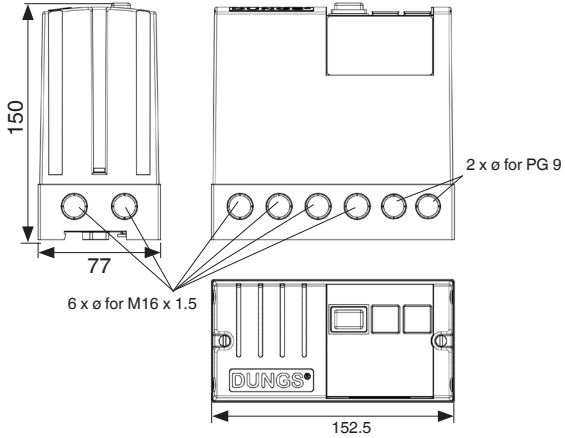

150

77

6 x \varnothing for M16 x 1.5

2 x \varnothing for PG 9

152.5

Installation

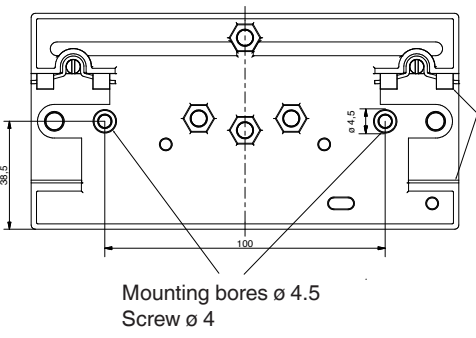



88.5

100

\varnothing 4.5

Mounting bores \varnothing 4.5
Screw \varnothing 4

Accessories		Hat rail mounting Mounting rail 35 mm
	Gas pressure switch Depending on the operating pressure, see data sheets LGW...A4 (5.08) GW...A6 (5.01) GW...A4 HP (5.04)	
	Pilot solenoid valves see data sheets DMV... (7.30, 7.37, 7.38), MV 502 (6.21) MVD ... (6.20) Pilot valve 3/2 way solenoid valve/MV...	
	MPA VisionBox As addition to MPA parameterisation and service box for setting VPM parameters via a PC/laptop.	

**Control unit for
system leakage tests**

**Type VPM-LC
(Line Check)**

DUNGS®
Combustion Controls

Subject to technical modification in the interest of technical progress.



Company address
Karl Dungs GmbH & Co. KG
Siemensstraße 6-10
D-73660 Urbach, Germany
Phone +49 (0)7181-804-0
Fax +49 (0)7181-804-166

Postal address
Karl Dungs GmbH & Co. KG
Postfach 12 29
D-73602 Schorndorf, Germany
e-mail: info@dungs.com
Internet: www.dungs.com